

ACC F-16C Yaw Control System

WIRING SCHEMATIC - P/N F16C-YCS

LM SERIAL EFFECTIVITY:
001,

DB-9 M

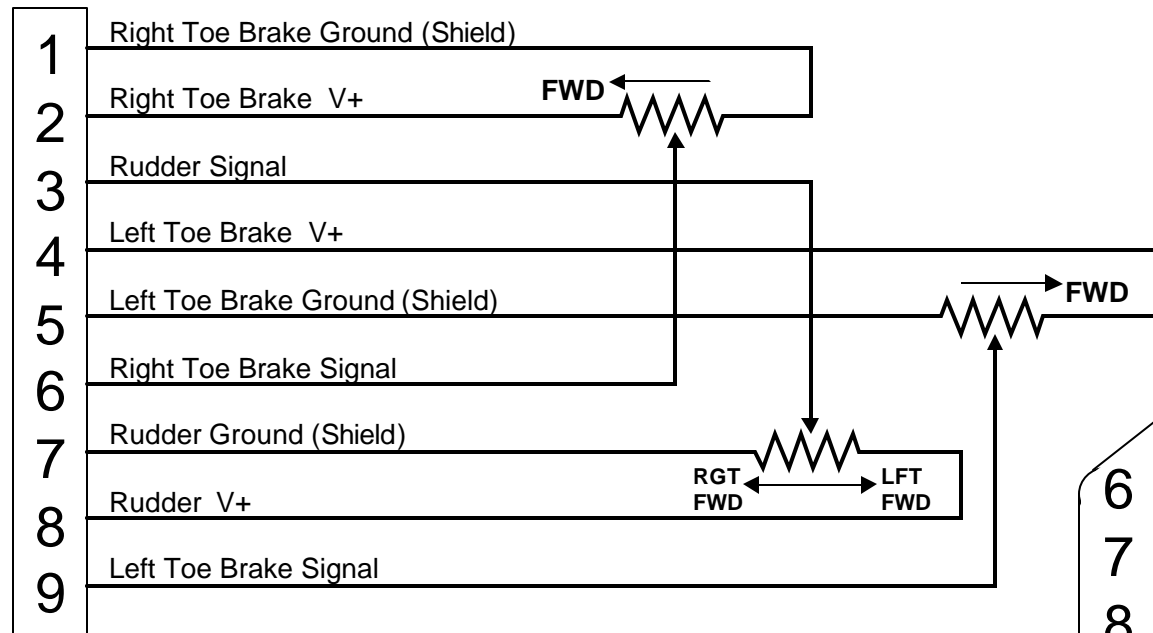

ALL POTS ARE 50k OHMS
ALL POT TRAVEL IS NEARLY 100%
POTS ARE SHOWN IN THEIR NORMAL POSITION

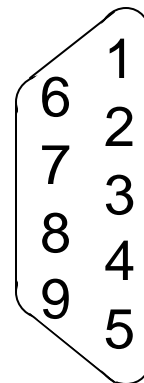

DB-9 M
LAYOUT
(Connector
- Front)

ACC F-16C Yaw Control System

WIRING SCHEMATIC - P/N F15C-YCS

**SERIAL EFFECTIVITY:
002, 003**

DB-9 F

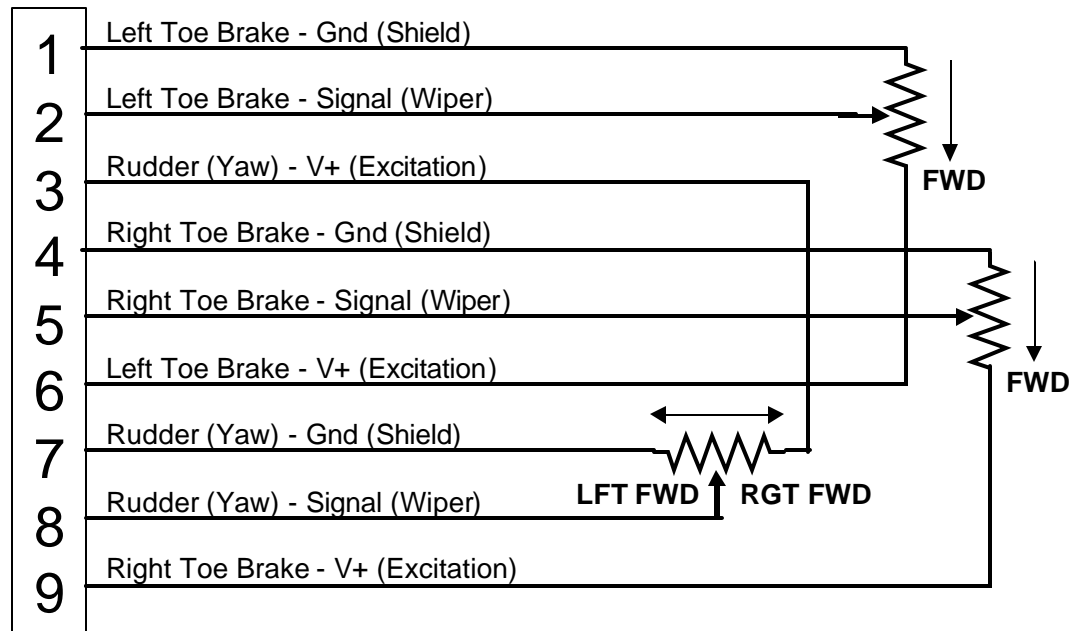

**ALL POTS ARE PROXIMATELY 25k OHMS
ALL POT TRAVEL IS NEARLY 100%
POTS ARE SHOWN IN THEIR NORMAL POSITION**

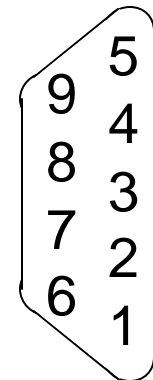

**DB-9 F
LAYOUT
(Connector
- Front)**